

NOORUL ISLAM COLLEGE OF ENGG

2 MARKS & QUESTION- ANSWERS LINEAR INTEGRATED CIRCUITS (EC1313)

Class: S4 EIE

Prepared by : D.JACKSON, Lecturer/EIE

UNIT I

1. Define an Integrated circuit.

An integrated circuit(IC) is a miniature ,low cost electronic circuit consisting of active and passive components fabricated together on a single crystal of silicon. The active components are transistors and diodes and passive components are resistors and capacitors.

2. What are the basic processes involved in fabricating ICs using planar technology?

- 1.Silicon wafer (substrate) preparation
- 2.Epitaxial growth
- 3.Oxidation
- 4.Photolithography
- 5.Diffusion
- 6.Ion implantation
- 7.Isolation technique
- 8.Metallization
- 9.Assembly processing & packaging

3. List out the steps used in the preparation of Si – wafers.

1. Crystal growth & doping
2. Ingot trimming & grinding
3. Ingot slicing
4. Wafer polishing & etching
5. Wafer cleaning

4. Write the basic chemical reaction in the epitaxial growth process of pure silicon.

The basic chemical reaction in the epitaxial growth process of pure silicon is the hydrogen reduction of silicon tetrachloride.

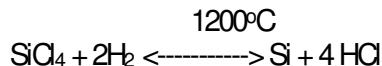

5. What are the two important properties of SiO₂?

1. SiO₂ is an extremely hard protective coating & is unaffected by almost all reagents except by hydrochloric acid. Thus it stands against any contamination.

2. By selective etching of SiO₂ , diffusion of impurities through carefully defined windows in the SiO₂ can be accomplished to fabricate various components.

6. Explain the process of oxidation.

The silicon wafers are stacked up in a quartz boat & then inserted into quartz furnace tube. The Si wafers are raised to a high temperature in the range of 950 to 1150°C & at the same time, exposed to a gas containing O₂ or H₂O or both. The chemical action is

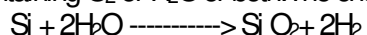

7. What is meant by molecular beam epitaxy(MBE)?

In the molecular beam epitaxy, silicon along with dopants is evaporated. The evaporated species are transported at a relatively high velocity in a vacuum to the substrate. The relatively low vapour pressure of silicon & the dopants ensures condensation on a low temperature substrate. Usually, silicon MBE is performed under ultra high vacuum (UHV) condition of 10^{-8} to 10^{-10} Torr.

8. What are the advantages of Molecular Beam Epitaxy(MBE)?

- (i) It is a low temperature process, useful for VLSI. This minimises outdiffusion & autodoping.
- (ii) It allows precise control of doping & permits complicated profiles to be generated.
- (iii) Linear doping profile desirable for varactor diode in FM, can be obtained with MBE.
- (iv) Wider choice of dopants can be used.

9. What are oxidation induced defects in semi conductor?

- 1. Stacking faults
- 2. Oxide isolation defects

Stacking faults:

Structural defects in the silicon lattice is called oxidation induced stacking faults. The growth of stacking faults is a strong function of substrate orientation, conductivity type & defect nuclei present. The stacking faults formation can be suppressed by the addition of HCl.

Oxide isolation defects :

The stress along the edges of an oxidised area produce severe damage in the silicon. Such defects results in increased leakage in nearby devices. High temperatures (around 950°C) will prevent stress induced defect formation.

10. What is bird's beak?

In local oxidation process, the oxidation of silicon proceeds slightly under the nitride as well. Also, a large mismatch in the thermal expansion co-efficients of Si_3N_4 & Silicon results in damage to the semi conductor during local oxidation. This damage can be greatly reduced by growing a thin layer of SiO_2 prior to placement of the Si_3N_4 mask. Typically 100 to 200\AA is used for this purpose. Unfortunately, this greatly enhances the penetration of oxide under the nitride masked regions, resulting in oxide configurations called bird's beak.

11. What is lithography?

Lithography is a process by which the pattern appearing on the mask is transferred to the wafer. It involves two steps: the first step requires applying a few drops of photoresist to the surface of the wafer & the second step is spinning the surface to get an even coating of the photoresist across the surface of the wafer.

12. What are the different types of lithography? What is optical lithography?

The different types of lithography are :

- 1. Photolithography
- 2. Electron beam lithography
- 3. X ray beam lithography
- 4. Ion beam lithography

Optical lithography:

Optical lithography comprises the formation images with visible or UV radiation in a photoresist using contact, proximity or projection printing.

13. What are the two processes involved in photolithography?

- a) Making a photographic mask
- b) Photo etching

The development of photographic mask involves the preparation of initial artwork and its reduction , decomposition of initial artwork or layout into several mask layers.

Photo etching is used for the removal of SiO₂ from desired regions so that the desired impurities can be diffused.

14. Distinguish between dry etching & wet etching.

Dry etching	Wet etching
1.Gaseous mixture is used as the chemical reagent.	Chemical reagents used are in the liquid form.
2.Smaller line openings($\leq 1\mu\text{m}$) are possible with dry etching	Line opening are larger.($> 1\mu\text{m}$)
3.It produces straight walled etching process.	It produces patterns with undercutting.

15. What is meant by reactive plasma etching?

The term reactive plasma is meant to describe a discharge in which ionization & fragmentation of gases takes place& produce chemically active plasma species, frequently oxidizers and reducing agents.

Such plasmas are reactive both in the gas phase & with solid surfaces exposed to them. When these interactions are used to form volatile products so that material is removed or etching of material form surfaces that are not masked to form lithographic patterns, the technique is known as reactive plasma etching.

16. What is isotropic & anisotropic etching processes?

Isotropic etching is a wet etching process which involves undercutting.

Aisotropic etching is a dry etching process which provides straight walled patterns.

17. Define diffusion.

The process of introducing impurities into selected regions of a silicon wafer is called diffusion. The rate at which various impurities diffuse into the silicon will be of the order of 1 $\mu\text{m/hr}$ at the temperature range of 900°C to 1100oC .The impurity atoms have the tendency to move from regions of higher concentrations to lower concentrations.

18. What is dielectric isolation?

In dielectric isolation, a layer of solid dielectric such as SiO₂ or ruby completely surrounds each components thereby producing isolation, both electrical & physical. This isolating dielectric layer is thick enough so that its associated capacitance is negligible. Also, it is possible to fabricate both pnp & npn transistors within the same silicon substrate.

19. What is metallization?

The process of producing a thin metal film layer that will serve to make interconnection of the various components on the chip is called metallization.

20. What are the advantages of ion implantation technique?

1. It is performed at low temperature. Therefore, previously diffused regions have a lesser tendency for lateral spreading.
2. In diffusion process, temperature has to be controlled over a large area inside the oven, whereas in ion implantation process, accelerating potential & beam content are dielectrically controlled from outside.

UNIT II

Characteristics of Op-Amp

1. What are the advantages of ICs over discrete circuits.?

1. Minimization & hence increased equipment density.
2. Cost reduction due to batch processing.
3. Increased system reliability
4. Improved functional performance.
5. Matched devices.
6. Increased operating speeds
7. Reduction in power consumption

2. What is OPAMP?

An operational amplifier is a direct coupled high gain amplifier consisting of one or more differential amplifiers, followed by a level translator and an output stage. It is a versatile device that can be used to amplify ac as well as dc input signals & designed for computing mathematical functions such as addition, subtraction, multiplication, integration & differentiation

3. Draw the pin configuration of IC741.

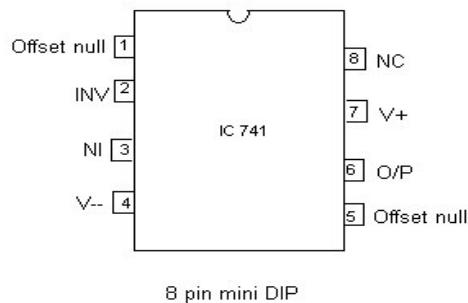

4. List out the ideal characteristics of OPAMP?

- (i) Open loop gain infinite
- (ii) Input impedance infinite
- (iii) Output impedance low
- (iv) Bandwidth infinite
- (v) Zero offset, i.e., $V_o = 0$ when $V_1 = V_2 = 0$

5. What are the different kinds of packages of IC741?

- a) Metal can (TO) package
- b) Dual-in-line package
- c) Flat package or flat pack

6. What are the assumptions made from ideal opamp characteristics?

- i) The current drawn by either of the input terminals (non-inverting/inverting) is negligible.
- ii) The potential difference between the inverting & non-inverting input terminals is zero.

7. Mention some of the linear applications of op-amps :

Adder, subtractor, voltage-to-current converter, current-to-voltage converters, instrumentation amplifier, analog computation, power amplifier, etc are some of the linear op-amp circuits.

8. Mention some of the non-linear applications of op-amps:-

Rectifier, peak detector, clipper, clamper, sample and hold circuit, log amplifier, anti-log amplifier, multiplier are some of the non-linear op-amp circuits.

9. What are the areas of application of non-linear op- amp circuits?

- * Industrial instrumentation
- * Communication
- * Signal processing

10. What happens when the common terminal of V⁺ and V⁻ sources is not grounded?

If the common point of the two supplies is not grounded, twice the supply voltage will get applied and it may damage the op-amp.

11. Define input offset voltage.

A small voltage applied to the input terminals to make the output voltage as zero when the two input terminals are grounded is called input offset voltage.

12. Define input offset current. State the reasons for the offset currents at the input of the op-amp.

The difference between the bias currents at the input terminals of the op-amp is called as input offset current. The input terminals conduct a small value of dc current to bias the input transistors. Since the input transistors cannot be made identical, there exists a difference in bias currents.

13. Define CMRR of an op-amp.

The relative sensitivity of an op-amp to a difference signal as compared to a common-mode signal is called the common-mode rejection ratio. It is expressed in decibels.

$$CMRR = A_d/A_c$$

14. In practical op-amps, what is the effect of high frequency on its performance?

The open-loop gain of op-amp decreases at higher frequencies due to the presence of parasitic capacitance. The closed-loop gain increases at higher frequencies and leads to instability.

15. What is the need for frequency compensation in practical op-amps?

Frequency compensation is needed when large bandwidth and lower closed loop gain is desired. Compensating networks are used to control the phase shift and hence to improve the stability.

16. Mention the frequency compensation methods.

- *Dominant-pole compensation
- *Pole-zero compensation.

17. What are the merits and demerits of Dominant-pole compensation?

- *noise immunity of the system is improved.
- *Open-loop bandwidth is reduced.

18. Define slew rate.

The slew rate is defined as the maximum rate of change of output voltage caused by a step input voltage. An ideal slew rate is infinite which means that op-amp's output voltage should change instantaneously in response to input step voltage.

19. Why IC 741 is not used for high frequency applications?

IC741 has a low slew rate because of the predominance of capacitance present in the circuit at higher frequencies. As frequency increases the output gets distorted due to limited slew rate.

20. What causes slew rate?

There is a capacitor with-in or outside of an op-amp to prevent oscillation. It is this capacitor which prevents the output voltage from responding immediately to a fast changing input.

21. Define thermal drift.

The bias current, offset current & offset voltage change with temperature. A circuit carefully nulled at 25°C may not remain so when the temperature raises to 35°C. This is called thermal drift. Often, offset current drift is expressed in nA/°C and offset voltage drift in mV/°C.

22. Define supply voltage rejection ratio (SVRR)

The change in OPAMP's input offset voltage due to variations in supply voltage is called the supply voltage rejection ratio. It is also called Power Supply Rejection Ratio (PSRR) or Power Supply Sensitivity (PSS).

UNIT III

Applications of Op Amp

1. What is the need for an instrumentation amplifier?

In a number of industrial and consumer applications, the measurement of physical quantities is usually done with the help of transducers. The output of transducer has to be amplified so that it can drive the indicator or display system. This function is performed by an instrumentation amplifier.

2. List the features of instrumentation amplifier:

- high gain accuracy
- high CMRR
- high gain stability with low temperature co-efficient
- low dc offset
- low output impedance

3. What is a comparator?

A comparator is a circuit which compares a signal voltage applied at one input of an op-amp with a known reference voltage at the other input. It is an open loop op-amp with output $\pm V_{sat}$.

4. What are the applications of comparator?

- * Zero crossing detectors
- * Window detector
- * Time marker generator
- * Phase detector

5. What is a Schmitt trigger?

Schmitt trigger is a regenerative comparator. It converts sinusoidal input into a square wave output. The output of Schmitt trigger swings between upper and lower threshold voltages, which are the reference voltages of the input waveform.

6. What is a multivibrator?

Multivibrators are a group of regenerative circuits that are used extensively in timing applications. It is a wave shaping circuit which gives symmetric or asymmetric square output. It has two states either stable or quasi-stable depending on the type of multivibrator.

7. What do you mean by monostable multivibrator?

Monostable multivibrator is one which generates a single pulse of specified duration in response to each external trigger signal. It has only one stable state. Application of a trigger causes a change to the quasi-stable state. An external trigger signal generated due to charging and discharging of the capacitor produces the transition to the original stable state.

8. What is an astable multivibrator?

Astable multivibrator is a free running oscillator having two quasi-stable states. Thus, there are oscillations between these two states and no external signal is required to produce the change in state.

9. What is a bistable multivibrator?

Bistable multivibrator is one that maintains a given output voltage level unless an external trigger is applied. Application of an external trigger signal causes a change of state, and this output level is maintained indefinitely until a second trigger is applied. Thus, it requires two external triggers before it returns to its initial state.

10. What are the requirements for producing sustained oscillations in feedback circuits?

For sustained oscillations,

* The total phase shift around the loop must be zero at the desired frequency of oscillation, f_o . i.e., $\angle A\beta = 0$ (or) 360°

* At f_o , the magnitude of the loop gain $|A\beta|$ should be equal to unity

11. What are the different types of filters?

Based on functions: Low pass filter, High pass filter, Band pass filter, Band reject filter

Based on order of transfer function: first, second, third higher order filters.

Based on configuration: Bessel, Chebychev, Butterworth filters.

12. List the broad classification of ADCs.

1. Direct type ADC.
2. Integrating type ADC.

13. List out the direct type ADCs.

1. Flash (comparator) type converter
2. Counter type converter
3. Tracking or servo converter
4. Successive approximation type converter

14. List out some integrating type converters.

1. Charge balancing ADC
2. Dual slope ADC

15. What is integrating type converter?

An ADC converter that performs conversion in an indirect manner by first changing the analog I/P signal to a linear function of time or frequency and then to a digital code is known as an integrating type A/D converter.

16. Explain in brief the principle of operation of successive Approximation ADC.

The circuit of successive approximation ADC consists of a successive approximation register (SAR), to find the required value of each bit by trial & error. With the arrival of START command, SAR sets the MSB bit to 1. The O/P is converted into an analog signal & it is compared with I/P signal. This O/P is low or High. This process continues until all bits are checked.

17. What are the main advantages of integrating type ADCs?

- i. The integrating type of ADC's do not need a sample/hold circuit at the input.
- ii. It is possible to transmit frequency even in noisy environment or in an isolated form.

18. Define conversion time.

It is defined as the total time required converting an analog signal into its digital output. It depends on the conversion technique used & the propagation delay of circuit components.

The conversion time of a successive approximation type ADC is given by

$T(n+1)$ Where T ---clock period T_c ---conversion time n - no. of bits

19. Define resolution of a data converter.

The resolution of a converter is the smallest change in voltage which may be produced at the output or input of the converter.

Resolution (in volts) = $V_{FS}/2^n - 1 = 1$ LSB increment. The resolution of an ADC is defined as the smallest change in analog input for a one-bit change at the output.

20. Explain in brief stability of a converter:

The performance of converter changes with temperature age & power supply variation. So all the relevant parameters such as offset, gain, linearity error & monotonicity must be specified over the full temperature & power supply ranges to have better stability performances.

21. What is meant by linearity?

The linearity of an ADC/DAC is an important measure of its accuracy & tells us how close the converter output is to its ideal transfer characteristics. The linearity error is usually expressed as a fraction of LSB increment or percentage of full-scale voltage. A good converter exhibits a linearity error of less than $\pm 1/2$ LSB.

22. What is a sample and hold circuit? Where it is used?

A sample and hold circuit is one which samples an input signal and holds on to its last sampled value until the input is sampled again. This circuit is mainly used in digital interfacing, analog to digital systems, and pulse code modulation systems.

23. Define sample period and hold period.

The time during which the voltage across the capacitor in sample and hold circuit is equal to the input voltage is called sample period. The time period during which the voltage across the capacitor is held constant is called hold period.

UNIT IV

1. What are the applications of 555 Timer?

- astable multivibrator
- monostable multivibrator
- Missing pulse detector
- Linear ramp generator
- Frequency divider
- Pulse width modulation
- FSK generator
- Pulse position modulator
- Schmitt trigger

2. List the applications of 555 timer in monostable mode of operation:

- ❖ missing pulse detector
- ❖ Linear ramp generator
- ❖ Frequency divider
- ❖ Pulse width modulation.

3. List the applications of 555 timer in Astable mode of operation:

- *FSK generator
- *Pulse-position modulator

4. Define 555 IC?

The 555 timer is an integrated circuit specifically designed to perform signal generation and timing functions.

5. List the basic blocks of IC 555 timer?

- A relaxation oscillator
- RS flip flop
- Two comparator
- Discharge transistor.
-

6. List the features of 555 Timer?

- It has two basic operating modes: monostable and astable
- It is available in three packages. 8 pin metal can , 8 pin dip, 14 pin dip.
- It has very high temperature stability.

7. Define duty cycle?

The ratio of high output and low output period is given by a mathematical parameter called duty cycle. It is defined as the ratio of ON Time to total time.

8. Define VCO.

A voltage controlled oscillator is an oscillator circuit in which the frequency of oscillations can be controlled by an externally applied voltage.

9. List the features of 566 VCO.

- Wide supply voltage range(10-24V)
- Very linear modulation characteristics
- High temperature stability

10. What does u mean by PLL?

A PLL is a basically a closed loop system designed to lock output frequency and phase to the frequency and phase of an input signal.

11. Define lock range.

When PLL is in lock, it can trap freq changes in the incoming signal. The range of frequencies over which the PLL can maintain lock with the incoming signal is called as lock range.

12. Define capture range.

The range of frequencies over which the PLL can acquire lock with the input signal is called as capture range.

13. Define pull-in time.

The total time taken by the PLL to establish lock is called pull-in time.

14. List the applications of 565 PLL

- Frequency multiplier
- Frequency synthesizer
- FM detector

15. What are the two types of analog multiplier Ics?

- a) IC AD 533
- b) IC AD 534

16. What is ICAD 533?

It is a multiplier IC by analog devices. It is a low cost IC comprising a transconductance multiplying element, stable reference and an output amplifier.

17. List the features of ICAD533.

- Its operation is very simple.
- Only 4 external adjustments are necessary
- Maximum 4 quadrant error is below 0.5%

18. What is ICAD 534?

It is a multiplier IC by analog devices. It is the first general purpose multiplier capable of providing gain upto X100.

19. List the features of ICAD534.

- Adjustable scale factor
- Low noise
- Excellent long time stability

20. List the few applications of ICAD534.

- Multiplier
- Divider
- High quality signal processing

UNIT V

1. What is a voltage regulator?

A voltage regulator is an electronic circuit that provides a stable dc voltage independent of the load current, temperature, and ac line voltage variations.

2. Give the classification of voltage regulators:

- *Series / Linear regulators
- *Switching regulators.

3. What is a linear voltage regulator?

Series or linear regulator uses a power transistor connected in series between the unregulated dc input and the load and it conducts in the linear region .The output voltage is controlled by the continuous voltage drop taking place across the series pass transistor.

4. What is a switching regulator?

Switching regulators are those which operate the power transistor as a high frequency on/off switch, so that the power transistor does not conduct current continuously. This gives improved efficiency over series regulators.

5. What are the advantages of IC voltage regulators?

- low cost., high reliability, reduction in size and excellent performance

6. Give some examples of monolithic IC voltage regulators:

- 78XX series fixed output, positive voltage regulators
- 79XX series fixed output, negative voltage regulators
- 723 general purpose regulator.

7. What is the purpose of having input and output capacitors in three terminal IC regulators?

A capacitor connected between the input terminal and ground cancels the inductive effects due to long distribution leads. The output capacitor improves the transient response.

8. Define line regulation.

Line regulation is defined as the percentage change in the output voltage for a change in the input voltage. It is expressed in millivolts or as a percentage of the output voltage.

9. Define load regulation.

Load regulation is defined as the change in output voltage for a change in load current. It is expressed in millivolts or as a percentage of the output voltage.

10. What is meant by current limiting?

Current limiting refers to the ability of a regulator to prevent the load current from increasing above a preset value.

11. Give the drawbacks of linear regulators:

The input step down transformer is bulky and expensive because of low line frequency. Because of low line frequency, large values of filter capacitors are required to decrease the ripple. Efficiency is reduced due to the continuous power dissipation by the transistor as it operates in the linear region.

12. What is the advantage of switching regulators?

Greater efficiency is achieved as the power transistor is made to operate as low impedance switch. Power transmitted across the transistor is in discrete pulses rather than as a steady current flow.

By using suitable switching loss reduction technique, the switching frequency can be increased so as to reduce the size and weight of the inductors and capacitors.

13. What is an opto-coupler IC?

Opto-coupler IC is a combined package of a photo-emitting device and a photo-sensing device.

14. What are the types of opto couplers?

- LED and a photo diode,
- LED and photo transistor,
- LED and Darlington.

15. Give two examples of IC optocouplers?

Examples for opto-coupler IC

- MCT 2F
- MCT 2E.

16. Mention the advantages of opto-couplers:

- Better isolation between the two stages.
- Impedance problem between the stages is eliminated.
- Wide frequency response.
- Easily interfaced with digital circuit.
- Compact and light weight.
- Problems such as noise, transients, contact bounce, are eliminated.

17. What is an isolation amplifier?

An isolation amplifier is an amplifier that offers electrical isolation between its input and output terminals.

18. What are the features of isolation amplifier?

- Easy to use , Ultra low leakage 18 pin DIP package

19. What is LM380?

It is a power amplifier produced by national semiconductor. It is capable of delivering 2.5 W min, to 8 ohm load.

20. What are the features of MA78s40?

- Step up, step down or inverting operation
- Operation from 2.5 to 40 V.
- 80Db line and load regulation.